

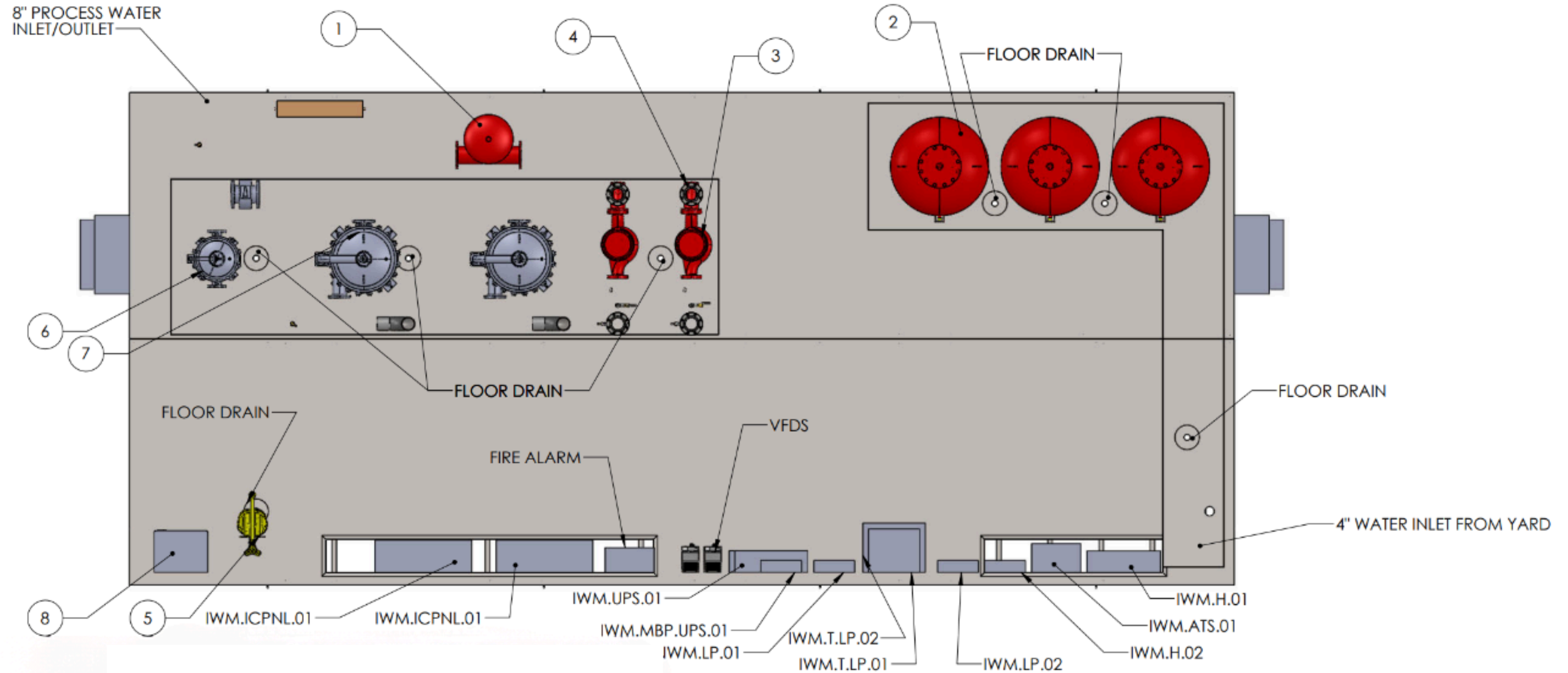

Sample Mechanical Enclosure Package

Example documentation for reference only.
Final drawings are project specific.

Mechanical Enclosure Package #1



Mechanical Enclosure Package #1



ITEM NO.	COMPONENT	QTY.
1	AIR SEPARATOR	1
2	EXPANSION TANK	3
3	PUMP	2
4	SUCTION DIFFUSER	3
5	-	-
6	FILTER HOUSING	1
7	FILTER HOUSING	2
8	ELECTRIC WATER HEATER	1
9	CORROSION COUPON RACK	1
10	HVAC UNIT	2

Mechanical Enclosure Package #1

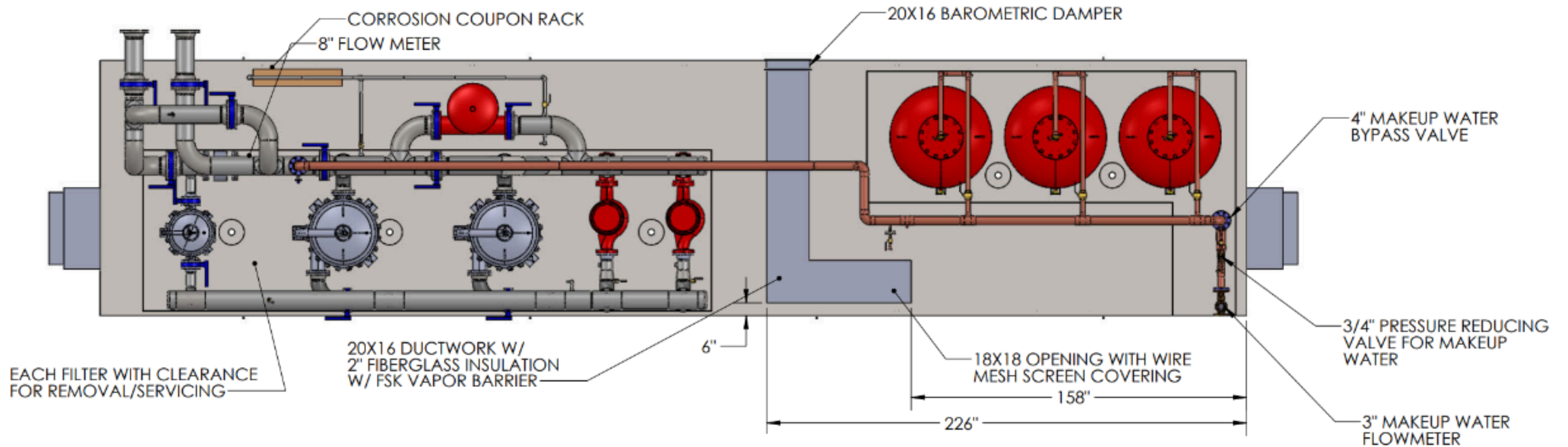

TOP VIEW

Mechanical Enclosure Package #1

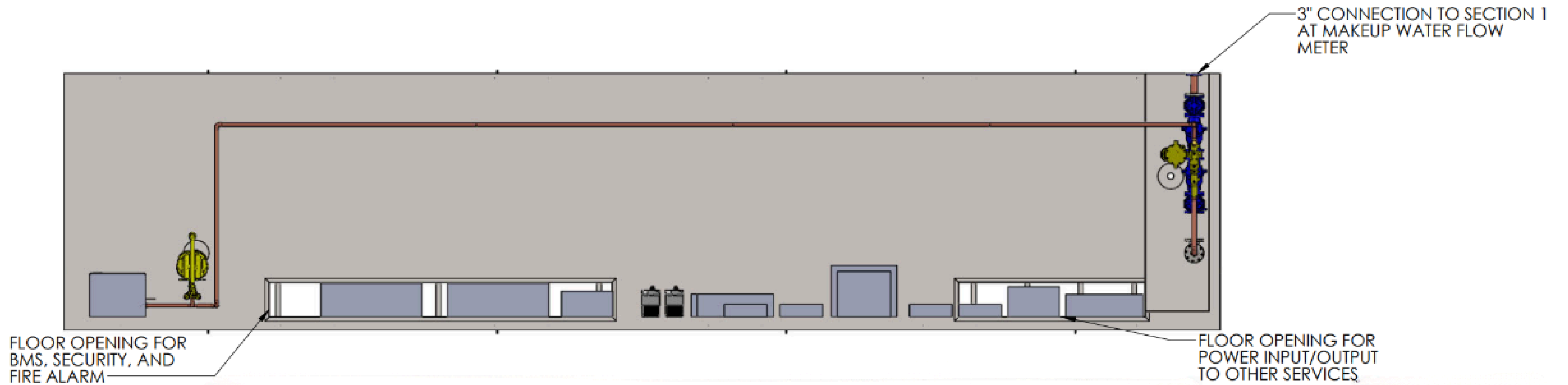

TOP VIEW

Mechanical Enclosure Package #1

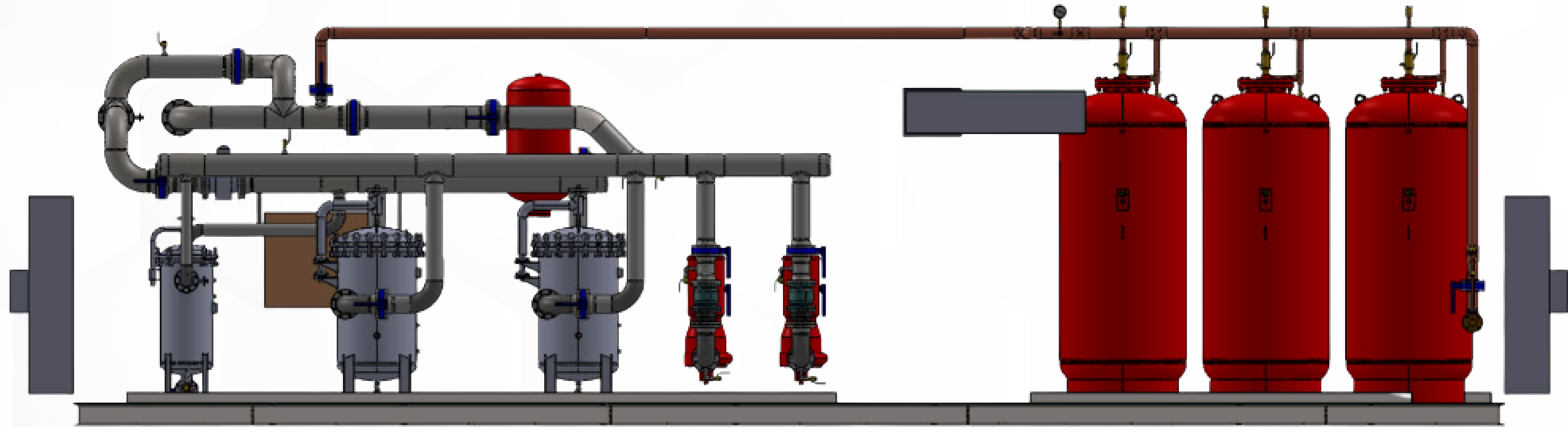

FRONT VIEW

Mechanical Enclosure Package #1

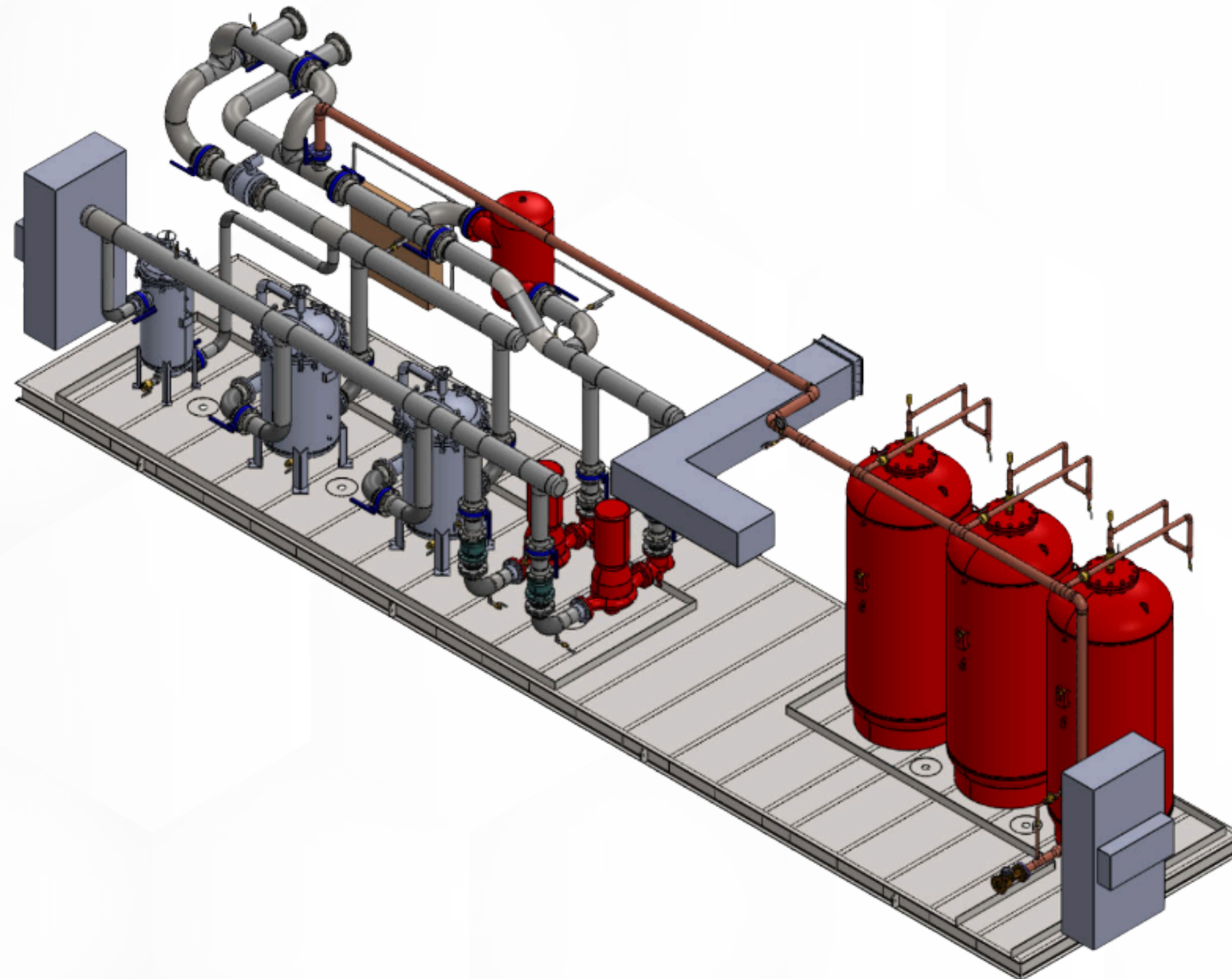

ISOMETRIC VIEW

Mechanical Enclosure Package #1

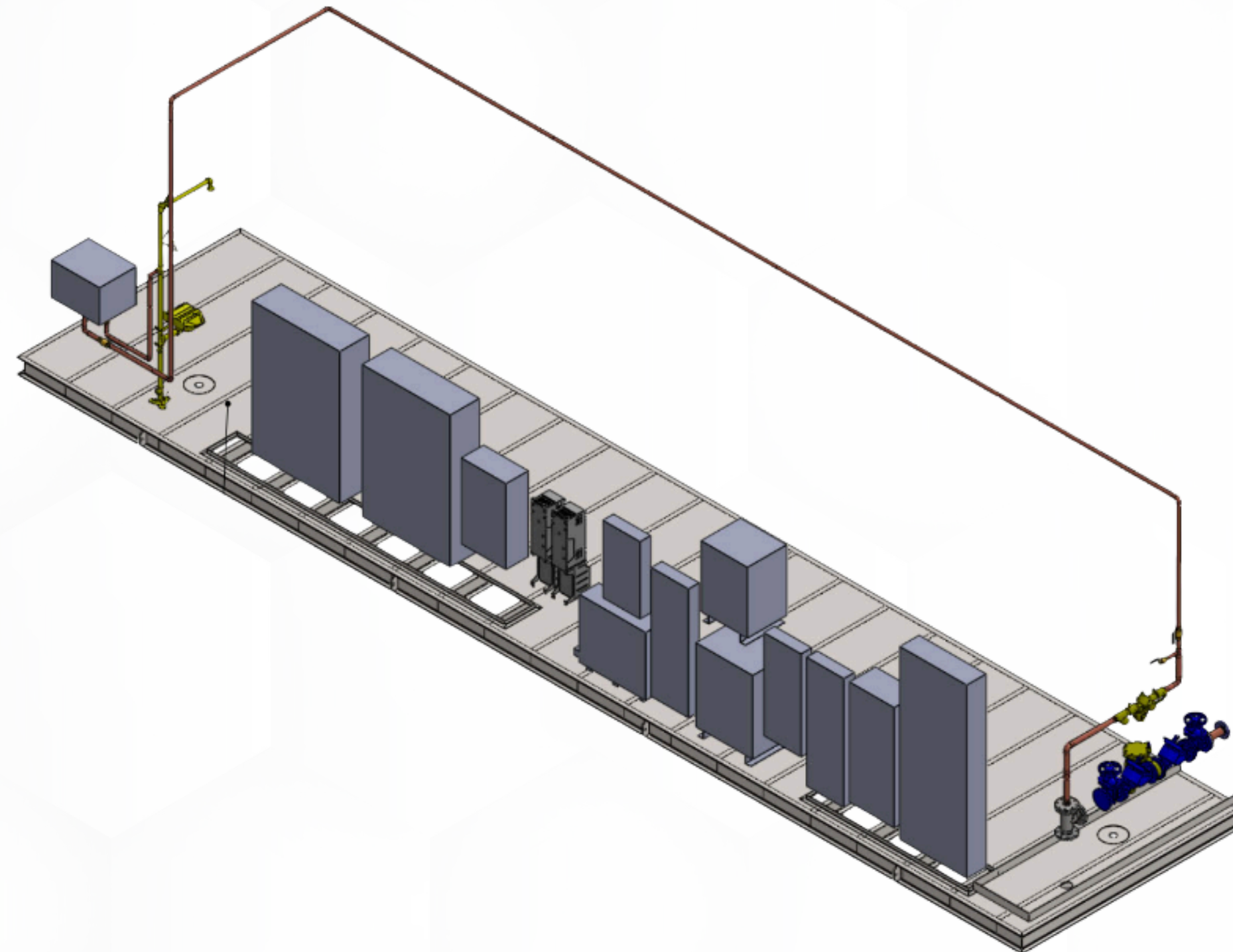

ISOMETRIC VIEW



Sample Mechanical Enclosure Package

Example documentation for reference only.
Final drawings are project specific.

Mechanical Enclosure Package #2



ITEM NO.	COMPONENT	QTY.
1	BOILER	3
2	PUMP	3
3	COALESCING REMOVAL SEPARATOR	1
4	EXPANSION TANK	1
5	COALESCING REMOVAL SEPARATOR	1
6	EXPANSION TANK	1
7	BASE MOUNTED PUMP	3
8	BASE MOUNTED PUMP	3
9	BASE MOUNTED PUMP	3
10	SUCTION DIFFUSER	6
11	SUCTION DIFFUSER	3
12	VARIABLE SPEED DRIVE	3
13	VARIABLE SPEED DRIVE	3
14	VARIABLE SPEED DRIVE	3
15	BACKFLOW PREVENTER	1
16	SHOT FEEDER	2
17	CORROSION COUPN RACK	2
18	HVAC UNIT	1

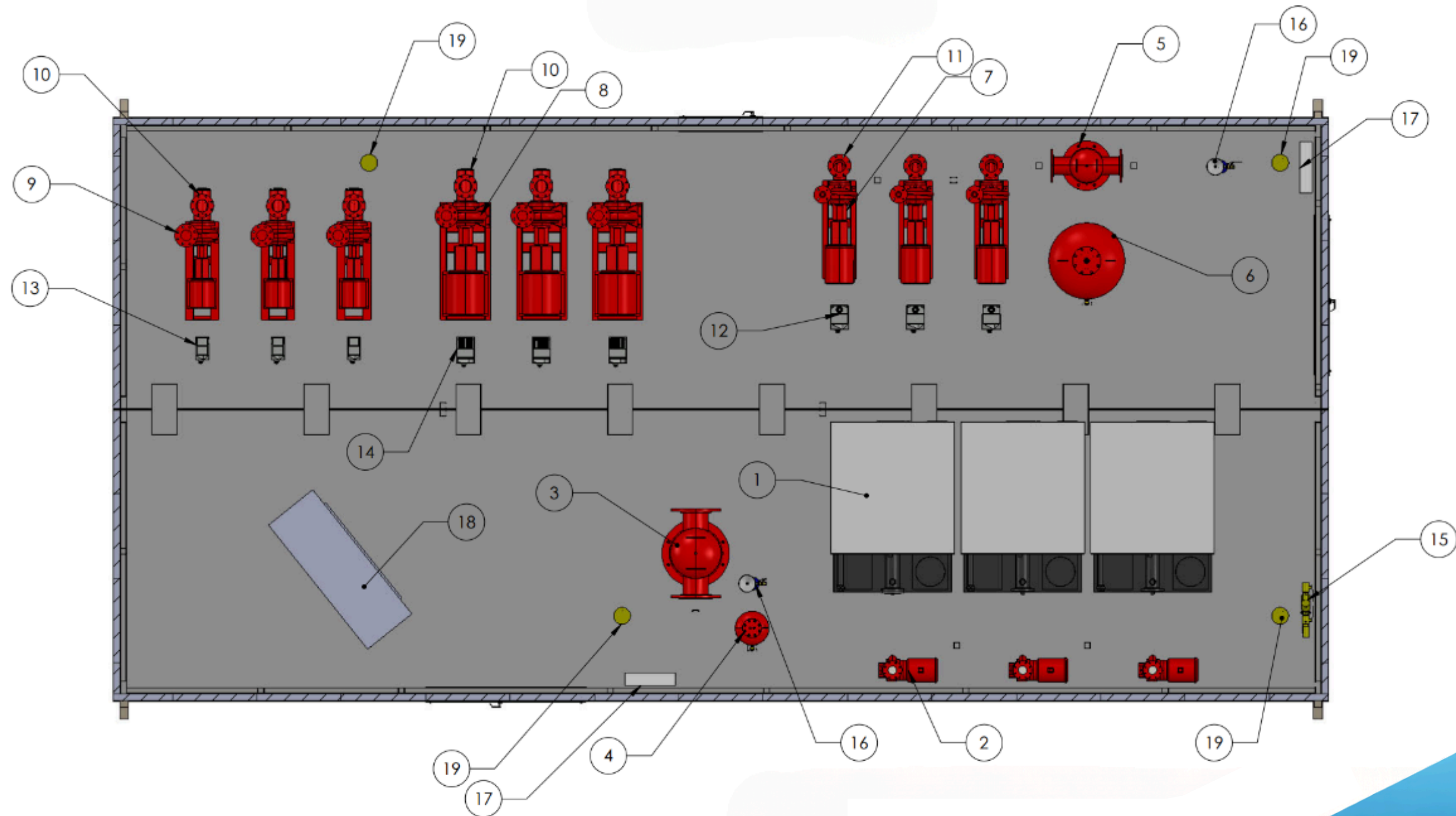

Mechanical Enclosure Package #2

PUMP DETAILS

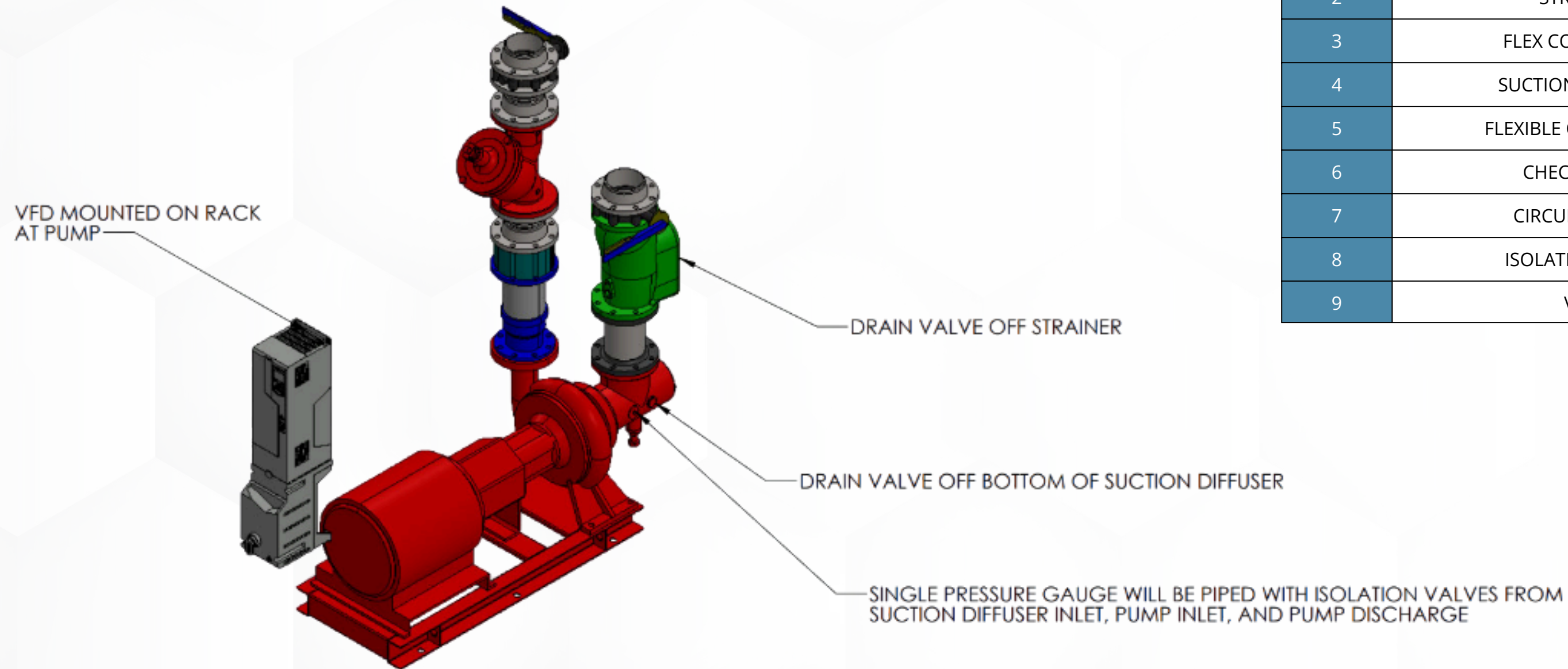

ITEM NO.	COMPONENT	QTY.
1	BASE MOUNTED PUMP	1
2	STRAINER	1
3	FLEX CONNECTOR	1
4	SUCTION DIFFUSER	1
5	FLEXIBLE CONNECTOR	1
6	CHECK VALVE	1
7	CIRCUIT SETTER	1
8	ISOLATION VALVE	2
9	VFD	1

Mechanical Enclosure Package #2

BOILER DETAILS

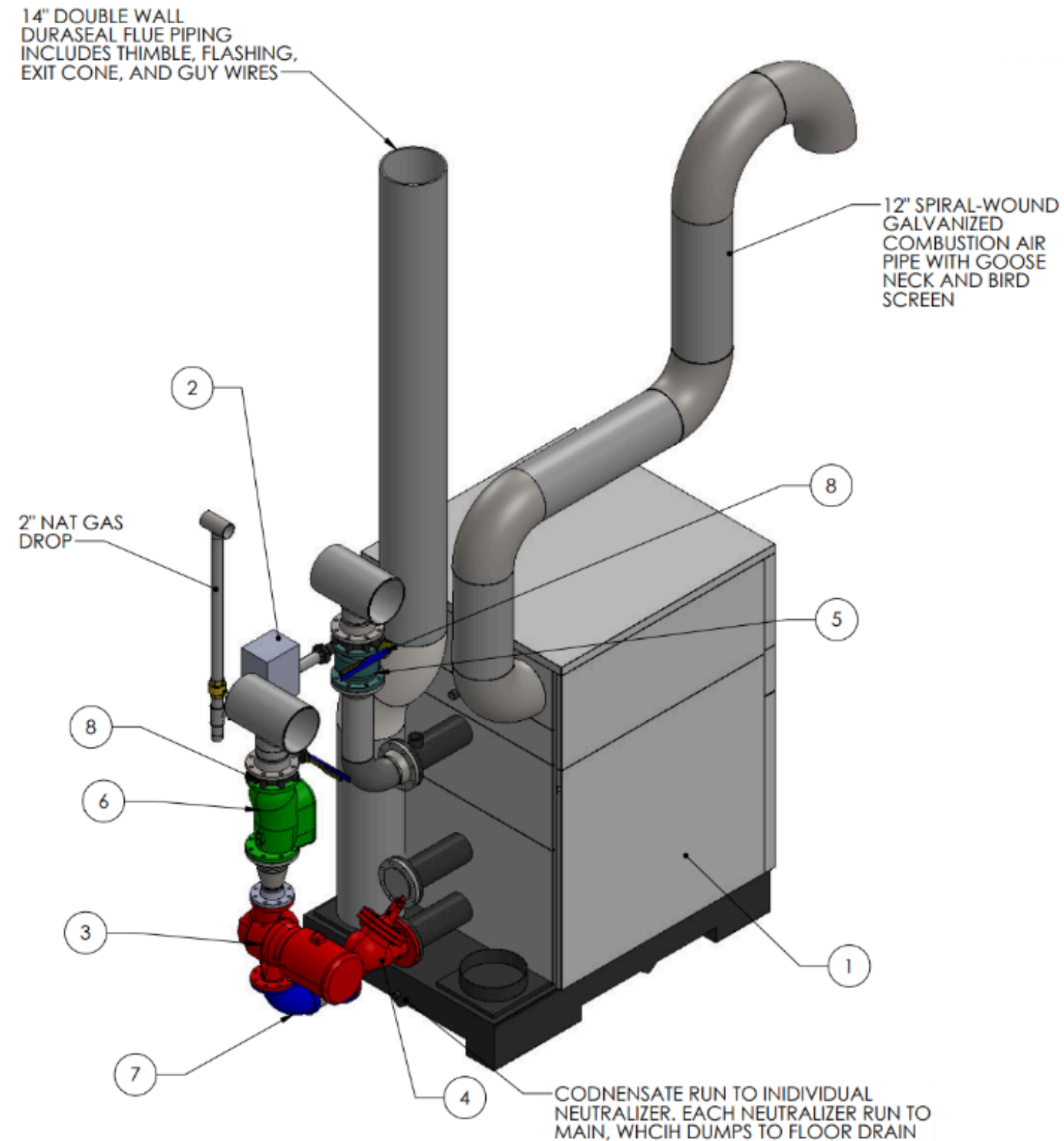

ITEM NO.	COMPONENT	QTY.
1	BOILER	1
2	NATURAL GAS REGULATOR	1
3	PUMP	1
4	CIRCUIT SETTER	1
5	CHECK VALVE	1
6	STRAINER	1
7	FLEXIBLE CONNECTOR	1
8	ISOLATION VALVE	2

Mechanical Enclosure Package #2

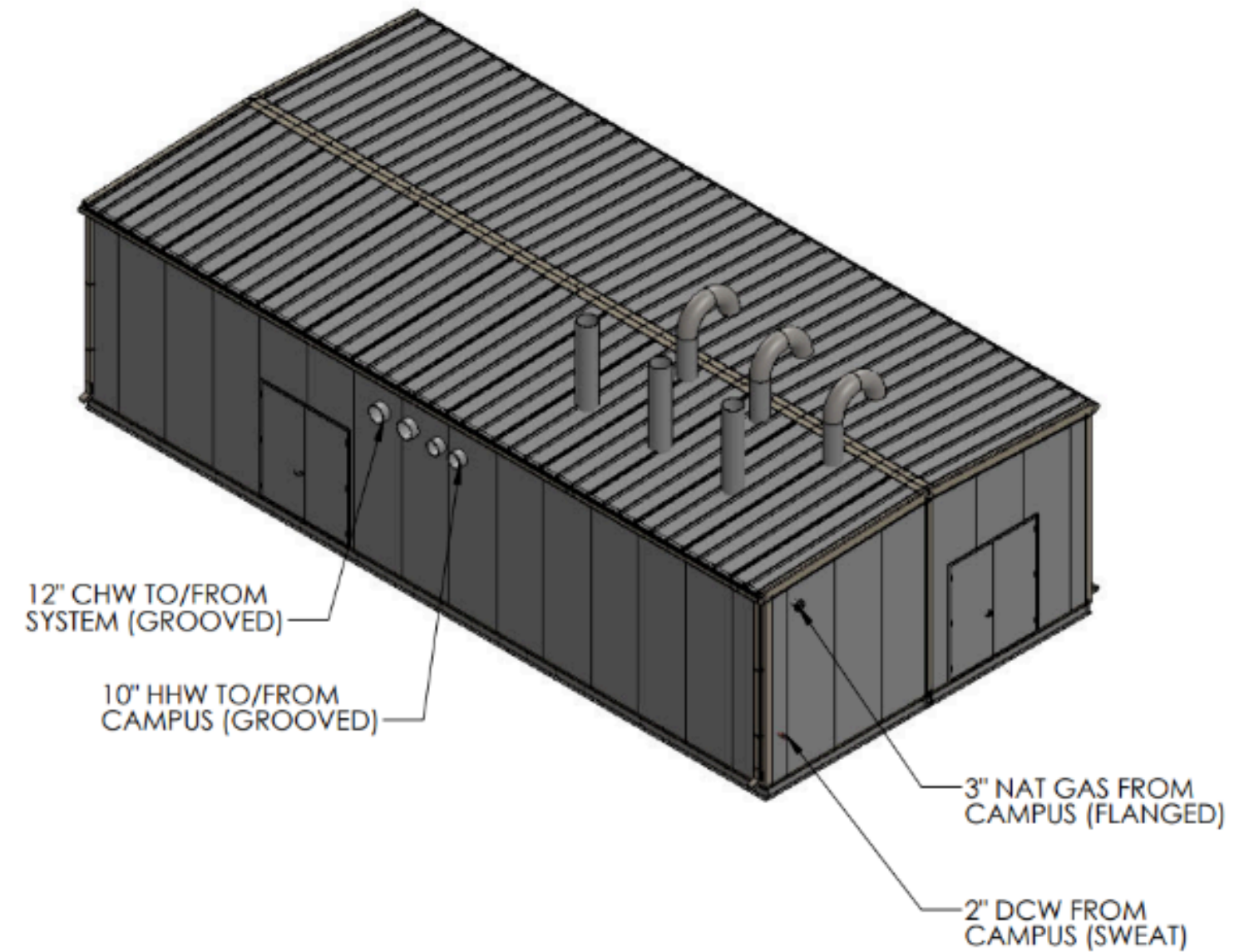
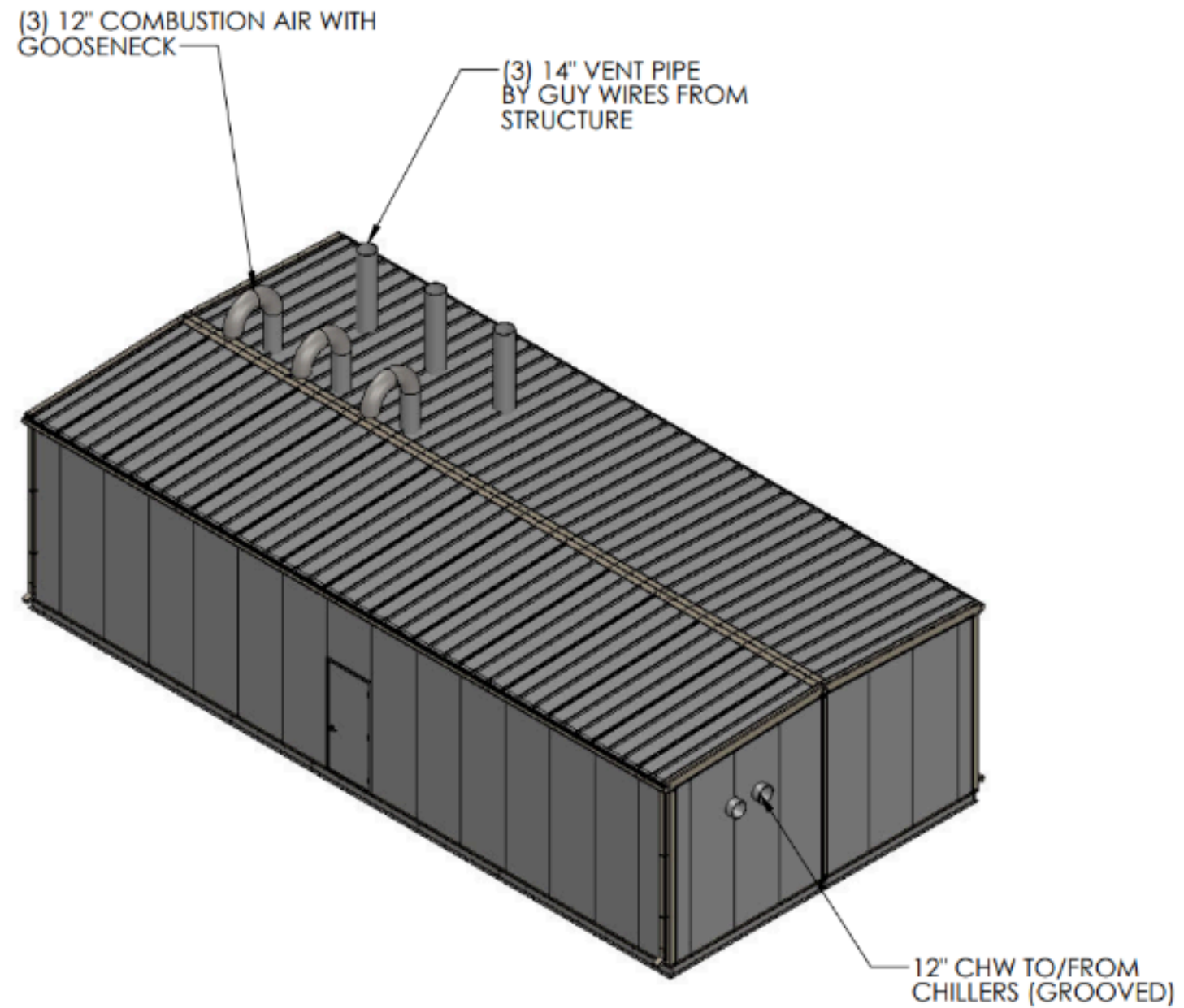

ISOMETRIC VIEW



Example documentation for reference only.
Final drawings are project specific.

To get more information and started with a
quote contact a rep.

[CONTACT A REP](#)